

1. General Description

The M8000 is a complete 8-channel analog-to-digital converter for digital audio systems. It performs sampling, analog-to-digital conversion, and anti-alias filtering, generating 24-bit values for all channel inputs in serial format at sample rates up to 216 kHz per channel.

The M8000 uses a 5th-order, multi-bit delta sigma modulator followed by low latency digital filtering and decimation, which removes the need for an external anti-aliasing filter. The ADC uses a differential input architecture which provides excellent noise rejection.

Dedicated level translators for the Serial Port and Control Port allow seamless interfacing between the M8000 and other devices operating over a wide range of logic levels. In addition, an on-chip oscillator driver provides clocking flexibility and simplifies design.

The M8000 supports a high-speed TDM interface which provides a serial output of 8 channels of audio data with sample rates up to 216 kHz within a single data stream. This reduces layout complexity and relieves input/output constraints in digital signal processors.

The M8000 is available in a Commercial grade (-10 °C to 85 °C) 48-pin LQFP package.

The M8000 is ideal for high-end and pro-audio systems requiring unrivaled sound quality, transparent conversion, wide dynamic range and negligible distortion, such as A/V receivers, digital mixing consoles, multi-channel recorders, outboard converters and digital effects processors.

Features:

- Advanced Multi-bit Delta-Sigma Architecture
- 24-Bit Conversion
- 115 dB Dynamic Range
- -105 dB THD+N
- Supports Audio Sample Rates up to 216 kHz
- Selectable Audio Interface Formats
 - Left-Justified, I²S, TDM
 - 8-Channel TDM Interface Formats
- Low Latency Digital Filter
- Less than 680 mW Power Consumption
- On-Chip Oscillator Driver
- Operation as System Clock Master or Slave
- Auto-Detect Speed in Slave Mode
- Differential Analog Architecture
- Separate 1.8 V to 5 V Logic Supplies for Control and Serial ports
- High-Pass Filter for DC Offset Calibration
- Overflow Detection

Additional Control Port Features

- Supports Standard I²C or SPI Control Interface
- Individual Channel HPF Disable
- Overflow Detection for Individual Channels
- Mute Control for Individual Channels
- Independent Power-Down Control per Channel Pair

2. Block Diagram and Pin Description

2.1 Block Diagram

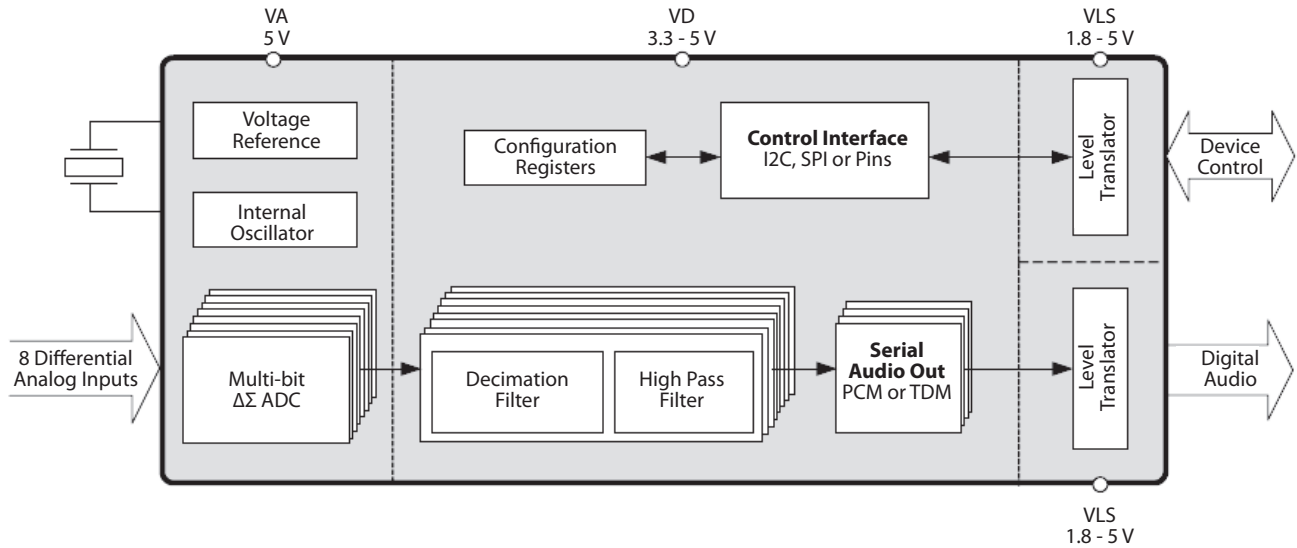

2.2 Pin Configurations

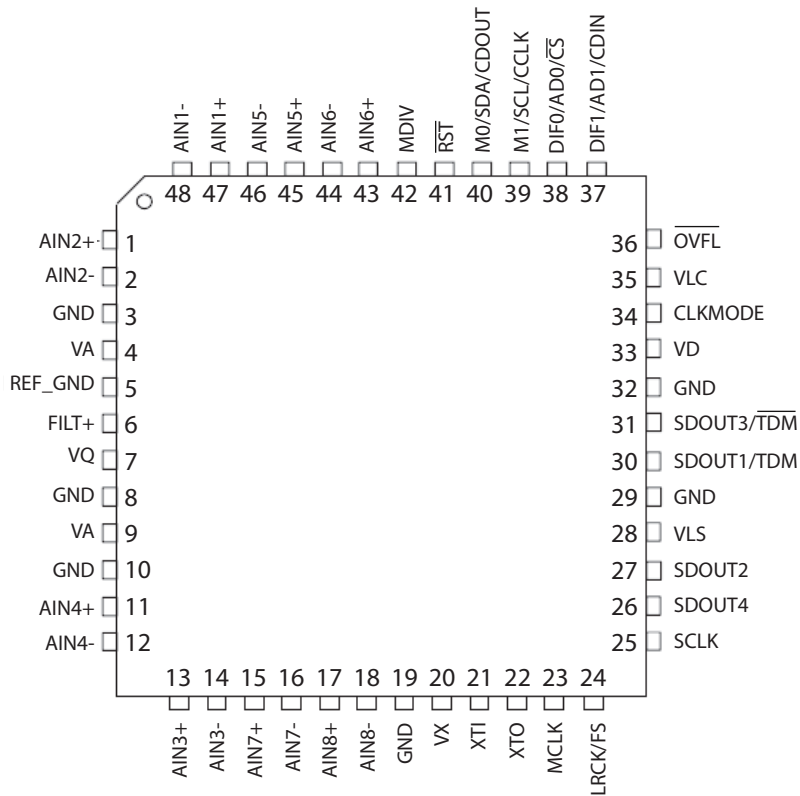

2.3 Pin Description

Pin No.	Pin Name	Description
1,2 11,12 13,14 15,16 17,18 43,44 45,46 47,48	AIN2+, AIN2- AIN4+, AIN4- AIN3+, AIN3- AIN7+, AIN7- AIN8+, AIN8- AIN6+, AIN6- AIN5+, AIN5- AIN1+, AIN1-	Differential Analog (Inputs) - Audio signals are presented differently to the delta sigma modulators via the AIN+/- pins.
3,8 10,19 29,32	GND	Ground (Input) - Ground reference. Must be connected to analog ground.
4,9	VA	Analog Power (Input) - Positive power supply for the analog section
5	REF_GND	Reference Ground (Input) - For the internal sampling circuits. Must be connected to analog ground.
6	FILT+	Positive Voltage Reference (Output) - Reference voltage for internal sampling circuits.
7	VQ	Quiescent Voltage (Output) - Filter connection for the internal quiescent reference voltage.
20	VX	Crystal Oscillator Power (Input) - Also powers control logic to enable or disable oscillator circuits.
21 22	XTI XTO	Crystal Oscillator Connections (Input/ Output) - I/O pins for an external crystal which may be used to generate MCLK.
23	MCLK	System Master Clock (Input/ Output) - When a crystal is used, this pin acts as a buffered MCLK Source (Output). When the oscillator function is not used, this pin acts as an input for the system master clock. In this case, the XTI and XTO pins must be tied low.
24	LRCK/FS	Serial Audio Channel Clock (Input/ Output) In I ² S Mode, Serial Audio Channel Select. When low, the odd channels are selected. In LJ Mode, Serial Audio Channel Select. When high, the odd channels are selected. In TDM Mode, a frame sync signal. When high, it marks the beginning of a new frame of serial audio samples. In Slave Mode, this pin acts as an input pin.
25	SCLK	Main timing clock for the Serial Audio Interface (Input/ Output) - During Master Mode, this pin acts as an output, and during Slave Mode it acts as an input pin.
26	SDOUT4	Serial Audio Data (Output) - Channels 7, 8.
27	SDOUT2	Serial Audio Data (Output) - Channels 3, 4.
28	VLS	Serial Audio Interface Power (Input) - Positive power for the serial audio interface.
30	SDOUT1/TDM	Serial Audio Data (Output) - Channels 1, 2.
31	SDOUT3/ \overline{TDM}	Serial Audio Data (Output) - Channels 5, 6. is complementary \overline{TDM} data.
33	VD	Digital Power (Input) - Positive power supply for the digital section.
35	VLC	Control Port Interface Power (Input) - Positive power for the control port interface.

Pin No.	Pin Name	Description
36	\overline{OVFL}	Overflow (Output, open drain) - Detects an overflow condition on both left and right channels.
41	\overline{RST}	Reset (Input) - The device enters a low power mode when low.
Stand-Alone Mode		
34	CLKMODE	CLKMODE (Input) - Setting this pin HIGH places a divide-by-1.5 circuit in the MCLK path to the core device circuitry.
37 38	DIF1 DIF0	DIF1, DIF0 (Input) - Inputs of the audio interface format.
39 40	M1 M0	Mode Selection (Input) - Determines the operational mode of the device.
42	MDIV	MCLK Divider (Input) - Setting this pin HIGH places a divide-by-2 circuit in the MCLK path to the core device circuitry.
Control Port Mode		
34	CLKMODE	CLKMODE (Input) - This pin is ignored in Control Port Mode and the same functionality is obtained from the corresponding bit in the Global Control Register. Note: Should be connected to GND when using the part in Control Port Mode.
37	AD1/CDIN	I²C Format, AD1 (Input) - Forms the device address input AD [1]. SPI Format, CDIN (Input) - Becomes the input data pin.
38	AD0/ \overline{CS}	I²C Format, AD0 (Input) - Forms the device address input AD [0]. SPI Format, CS (Input) - Acts as the active low chip select input.
39	SCL/CCLK	I²C Format, SCL (Input) – Serial clock for the serial control port. An external pull-up resistor is required for I ² C control port operation. SPI Format, CCLK (Input) – Serial clock for the serial control port.
40	SDA/CDOOUT	I²C Format SDA (Input/ Output) - Acts as an input/output data pin. An external pull-up resistor is required for I ² C control port operation. SPI Format CDOOUT (Output) - Acts as an output only data pin.
42	MDIV	MCLK Divider (Input) - This pin is ignored in Control Port Mode and the same functionality is obtained from the corresponding bit in the Global Control Register. Note: Should be connected to GND when using the part in Control Port Mode.

3. Electrical Parameter

3.1 Absolute Maximum Ratings

Operation beyond these limits may result in permanent damage to the device. Normal operation is not guaranteed at these extremes. Transient currents up to ± 100 mA on the analog input pins will not cause SCR latch-up.

Characteristic	Symbol	Min	Typ	Max	Units	
DC Power Supplies:	Positive Analog	VA	-0.3		+6.0	V
	Positive Crystal	VX	-0.3		+6.0	
	Positive Digital	VD	-0.3		+6.0	
	Positive Serial Logic	VLS	-0.3		+6.0	
	Positive Control Logic	VLC	-0.3		+6.0	
Input Current	I _{in}	-10	—	10	mA	
Analog Input Voltage	V _{IN}	-0.3		VA+0.3	V	
Digital Input Voltage	V _{IND}			VL+0.3		
Ambient Operating Temperature (Power Applied)	T _A	-50		95	°C	
Storage Temperature	T _{stg}	-65	150			

3.2 Recommended Operating Conditions

GND = 0 V, all voltages with respect to 0 V.

Characteristic	Symbol	Min	Typ	Max	Units	
DC Power Supplies:	Positive Analog	VA	4.75	5.0	5.25	V
	Positive Crystal	VX	4.75	5.0		
	Positive Digital	VD	3.14	3.3		
	Positive Serial Logic	VLS	1.71	3.3		
	Positive Control Logic	VLC	1.71	3.3		
Ambient Operating Temperature	T _{AC}	-10	—	85	°C	

3.3 System Clocking

Parameter	Symbol	Min	Typ	Max	Units
Input Master Clock Frequency	M _{CLK}	0.512		55.05	MHz
Input Master Clock Duty Cycle	t _{clkhl}	40		60	%

3.4 DC Power

Parameter	Symbol	Min	Typ	Max	Units
Power Supply Current (Normal Operation)	VA = 5 V	IA	100	112	mA
	VX = 5 V	IX	4	8	
	VD = 5 V	ID	—	70	
	VD = 3.3 V	ID	—	42	
	VLS, VLC = 5 V	IL	—	12	
	VLS, VLC = 3.3 V	IL	—	5	
Power Supply Current (Power-Down) (Note 1)	VA = VX = 5 V VLS, VLC, VD = 5 V	IA ID+L	— 500	—	μA
Power Consumption Normal Operation All Supplies = 5 V VA = VX = 5 V, VD = VLS = VLC = 3.3 V (Power-Down) (Note 1)	—	—	930 675 2.75	1115 792 —	mW

1. Power-Down is defined as \overline{RST} = LOW with all clocks and data lines held static at a valid logic level.

3.5 Logic levels

Parameter	Symbol	Min	Typ	Max	Units
High-Level Input Voltage	%VLS/VLC	VIH	70	—	%
Low-Level Input Voltage	%VLS/VLC	VIL	—	30	
High-Level Output Voltage at 100 μA load	%VLS/VLC	VOH	85	—	
Low-Level Output Voltage at -100 μA load	%VLS/VLC	VOL	—	15	
OVFL Current Sink			-4		mA
Input Leakage Current	logic pins only	lin	-10	10	μA

3.6 PSRR, VQ AND FILT+ CHARACTERISTICS

MCLK = 12.288 MHz; Master Mode. Valid with the recommended capacitor values on FILT+ and VQ as shown in the "Typical Connection Diagram".

Parameter	Symbol	Min	Typ	Max	Units
Power Supply Rejection Ratio at (1 kHz)	PSRR	—	65	—	dB
VQ Nominal Voltage			VA/2		V
Output Impedance			25	—	kΩ
Maximum allowable DC current source/sink			10		μA
Filt+ Nominal Voltage			VA		V
Output Impedance		—	4.4	—	kΩ
Maximum allowable DC current source/sink			10		μA

3.7 ANALOG CHARACTERISTICS (COMMERCIAL)

Test Conditions (unless otherwise specified). $V_A = 5\text{ V}$, $V_D = V_{LS} = V_{LC} 3.3\text{ V}$, and $T_A = 25\text{ }^\circ\text{C}$. Full-scale input sine wave. Measurement Bandwidth is 10 Hz to 20 kHz.

Parameter	Symbol	Min	Typ	Max	Unit	
Single-Speed Mode $F_s = 48\text{ kHz}$						
Dynamic Range	A-weighted	108	115	—	dB	
	un-weighted	105	111	—		
Total Harmonic Distortion + Noise referred to typical full scale	-1 dB	THD+N	—	-105	dB	
	-20 dB			-91		
	-60 dB			-51		-45
Double-Speed Mode $F_s = 96\text{ kHz}$						
Dynamic Range	A-weighted	108	115	—	dB	
	Un-weighted	105	111			
	40 kHz bandwidth un-weighted	—	108			
Total Harmonic Distortion + Noise referred to typical full scale	-1 dB	THD+N	108	-105	dB	
	-20 dB			-91		
	-60 dB			-51		-45
	40 kHz bandwidth -1 dB			—		-102
Quad-Speed Mode $F_s = 192\text{ kHz}$						
Dynamic Range	A-weighted	108	115	—	dB	
	un-weighted	105	111			
	40 kHz bandwidth un-weighted	—	108			
Total Harmonic Distortion + Noise referred to typical full scale	-1 dB	THD+N	—	-105	dB	
	-20 dB			-91		
	-60 dB			-51		-45
	40 kHz bandwidth -1dB			—		-102
Dynamic Performance for All Modes						
Interchannel Isolation		—	110	—	dB	
DC Accuracy						
Inter Channel Gain Mismatch		—	0.1	—	dB	
Gain Error		-7		7	%	
Gain Drift		—	± 100		ppm/ $^\circ\text{C}$	
Offset Error HPF enabled HPF disabled		0	—	—	LSB	
		—	—	100		
Analog Input Characteristics						
Full-scale Differential Input Voltage		$1.07*V_A$	$1.13*V_A$	$1.19*V_A$	V_{pp}	
Input Impedance (Differential)			250	—	$k\Omega$	
Common Mode Rejection Ratio	CMRR	—	82	—	dB	

3.8 DIGITAL FILTER CHARACTERISTICS

Parameter	Symbol	Min	Typ	Max	Unit
Single-Speed Mode (2 kHz to 54 kHz sample rates)					
Pass Band (Note 1)	(-0.1 dB)	0	—	0.47	Fs
Pass Band Ripple		-0.035		0.035	dB
Stop Band (Note 1)		0.58		Fs	
Stop Band (Note 1)		-95		dB	
Total Group Delay (Fs = Output Sample Rate)	tgd	—		12/Fs	s
Double-Speed Mode (54 kHz to 108 kHz sample rates)					
Pass Band (Note 1)	(-0.1 dB)	0	—	0.45	Fs
Pass Band Ripple		-0.035		0.035	dB
Stop Band (Note 1)		0.68		Fs	
Stop Band (Note 1)		-92		dB	
Total Group Delay (Fs = Output Sample Rate)	tgd	—		9/Fs	s
Quad-Speed Mode (108 kHz to 216 kHz sample rates)					
Pass Band (Note 1)	(-0.1 dB)	0	—	0.24	Fs
Pass Band Ripple		-0.035		0.035	dB
Stop Band (Note 1)		0.78		Fs	
Stop Band (Note 1)		-92		dB	
Total Group Delay (Fs = Output Sample Rate)	tgd	—		5/Fs	s
High-Pass Filter Characteristics					
Frequency Response (Note 2)	-3.0 dB -0.13 dB	—	1 20	—	Hz
Phase Deviation (Note 2) @ 20 Hz		—	10	—	Deg
Pass band Ripple			—	0	dB
Filter Settling Time			105/Fs	—	s

Notes:

1. The filter frequency response scales precisely with Fs.
2. Response shown is for Fs equal to 48 kHz. Filter characteristics scale with Fs.

3.9 OVERFLOW TIMEOUT

Parameter	Symbol	Min	Typ	Max	Unit
OVFL time-out on overrange condition			(217-1)/		
Fs = 44.1 kHz		—	Fs2972		ms
Fs = 192 kHz			683		

3.10 SERIAL AUDIO INTERFACE - I²S/LJ TIMING

The serial audio port is a three-pin interface consisting of SCLK, LRCK and SDOUT.

Logic "0" = GND = 0 V; Logic "1" = VLS; CL = 20 pF, timing threshold is 50% of VLS.

Parameter	Symbol	Min	Typ	Max	Unit
Sample Rates	Single-Speed Mode	2	—	54	kHz
	Double-Speed Mode	54	—	108	
	Quad-Speed Mode	108	—	216	
Master Mode					
SCLK Frequency	—	64*Fs	—	64*Fs	Hz
SCLK Period	1/(64*216 kHz)	t _{PERIOD}	—	—	ns
SCLK Duty Cycle (Note 1)	(CLKMODE = 0) (Note 2)	t _{HIGH}	50	60	%
	(CLKMODE = 1)(Note 2)	t _{HIGH}	28	33	%
LRCK setup	before SCLK rising	t _{SETUP1}	20	—	ns
LRCK hold	after SCLK rising	t _{HOLD1}	20	—	
SDOUT setup	before SCLK rising	t _{SETUP2}	10	—	ns
SDOUT hold	after SCLK rising (VLS = 1.8 V)	t _{HOLD2}	20	—	
	after SCLK rising (VLS = 3.3 V)	t _{HOLD2}	10	—	
	after SCLK rising (VLS = 5 V)	t _{HOLD2}	5	—	
Slave Mode					
SCLK Frequency(Note 3)	—	—	64*Fs	—	Hz
SCLK Period	1/(64*216 kHz)	t _{PERIOD}	72.3	—	ns
SCLK Duty Cycle	—	t _{HIGH}	28	65	%
LRCK setup	before SCLK rising	t _{SETUP1}	20	—	ns
LRCK hold	after SCLK rising	t _{HOLD1}	20	—	
SDOUT setup	before SCLK rising (VLS = 1.8 V)	t _{SETUP2}	4	—	ns
	before SCLK rising (VLS = 3.3 V)	t _{SETUP2}	10	—	
	before SCLK rising (VLS = 5 V)	t _{SETUP2}	10	—	
SDOUT hold	after SCLK rising (VLS = 1.8 V)	t _{HOLD2}	20	—	
	after SCLK rising (VLS = 3.3 V)	t _{HOLD2}	10	—	
	after SCLK rising (VLS = 5 V)	t _{HOLD2}	5	—	

Notes:

1. Duty cycle of generated SCLK depends on duty cycle of received MCLK as specified under "System Clocking" on page 5.
2. CLKMODE functionality described in Section 4.6.3 "Master Mode Clock Dividers" on page 18.
3. In Slave Mode, the SCLK/LRCK ratio can be set according to preference. However, chip performance is guaranteed only when using the ratios in Section 4.7 Master and Slave Clock Frequencies on page 19.

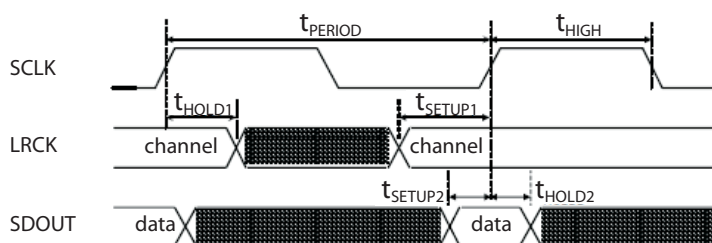

Figure 2. I²S/LJ Timing

3.11 SERIAL AUDIO INTERFACE - TDM TIMING

The serial audio port is a three-pin interface consisting of SCLK, LRCK and SDOUT.

Logic "0" = GND = 0 V; Logic "1" = VLS; CL = 20 pF, timing threshold is 50% of VLS.

Parameter	Symbol	Min	Typ	Max	Unit
Sample Rates	Single-Speed Mode	2	—	54	kHz
Double-Speed Mode	—	54	—	108	
Quad-Speed Mode	—	108	—	216	
Master Mode					
SCLK Frequency	—	256*Fs	—	256*Fs	Hz
SCLK Period	1/(256*216 kHz)	t_{PERIOD}	18	—	ns
SCLK Duty Cycle (Note 1)	(CLKMODE = 0)(Note 3)	t_{HIGH}	40	50	%
	(CLKMODE = 1)(Note 3)	t_{HIGH}	28	33	%
FS setup before SCLK rising (Single-Speed Mode)	t_{SETUP1}	20	—	—	ns
FS setup before SCLK rising (Double-Speed Mode)	t_{SETUP1}	18	—	—	ns
FS setup before SCLK rising (Quad-Speed Mode)	t_{SETUP1}	5	—	—	ns
FS width in SCLK cycles	t_{HIGH2}	128	—	128	—
SDOUT setup before SCLK rising	t_{SETUP2}	5	—	—	ns
SDOUT hold after SCLK rising	t_{HOLD2}	5	—	—	ns
Slave Mode					
SCLK Frequency (Note 4)	—	—	256*Fs	—	Hz
SCLK Period	1/(256*216 kHz)	t_{PERIOD}	18	—	ns
SCLK Duty Cycle	—	t_{HIGH}	28	65	%
FS setup before SCLK rising (Single-Speed Mode)	t_{SETUP1}	20	—	—	ns
FS setup before SCLK rising (Double-Speed Mode)	t_{SETUP1}	20	—	—	ns
FS setup before SCLK rising (Quad-Speed Mode)	t_{SETUP1}	10	—	—	ns
FS width in SCLK cycles	t_{HIGH2}	1	—	244	—
SDOUT setup before SCLK rising	t_{SETUP2}	5	—	—	ns
SDOUT hold after SCLK rising	t_{HOLD2}	5	—	—	ns

Notes:

1. TDM Quad-Speed Mode only specified to operate correctly at VLS \geq 3.14 V.
2. Duty cycle of generated SCLK depends on duty cycle of received MCLK as specified under "System Clocking" on page 5.
3. CLKMODE functionality described in Section 4.6.3 "Master Mode Clock Dividers" on page 18.
4. In Slave Mode, the SCLK/LRCK ratio can be set according to preference; chip performance is guaranteed only when using the ratios in Section 4.7 Master and Slave Clock Frequencies on page 19.

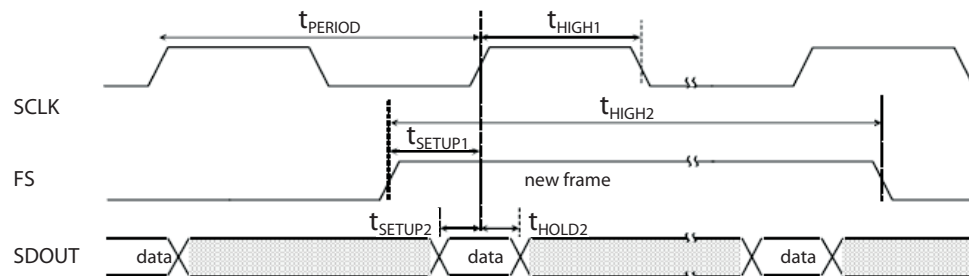

Figure 3. TDM Timing

3.12 SWITCHING SPECIFICATIONS - CONTROL PORT - I²C TIMING

Inputs: Logic 0 = DGND, Logic 1 = VLC, SDA CL = 30 pF

Parameter	Symbol	Min	Max	Unit
SCL Clock Frequency	f_{scl}	—	100	kHz
Rising Edge to Start	t_{irs}	600		ns
Bus Free Time Between Transmissions	t_{buf}	4.7		μ s
Start Condition Hold Time (prior to first clock pulse)	t_{hdst}	4		μ s
Clock Low time	t_{low}	4.7	—	
Clock High Time	t_{high}	4		
Setup Time for Repeated Start Condition	t_{sust}	4.7		
SDA Hold Time from SCL Falling (Note 1)	t_{hdd}	0		μ s
SDA Setup time to SCL Rising	t_{sud}	600		
SDA Setup time to SCL Rising	t_{sud}	—	1	μ s
Fall Time SCL and SDA	t_{fc}	—	300	ns
Setup Time for Stop Condition	t_{susp}	4.7	—	μ s
Acknowledge Delay from SCL Falling	t_{ack}	300	1000	ns

Notes:

1. Data must be held for sufficient time to bridge the transition time, t_{fc} , of SCL.

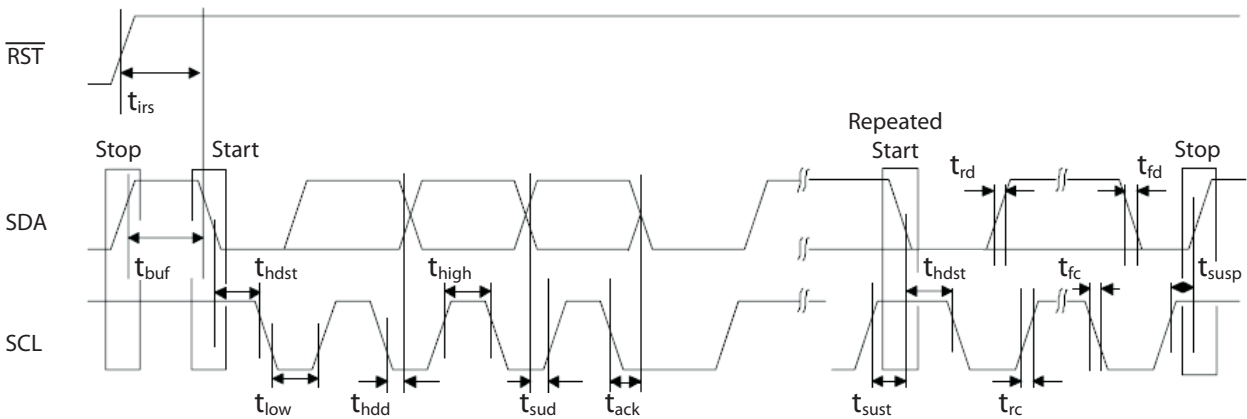

Figure 4. I²C Timing

3.13 SWITCHING SPECIFICATIONS - CONTROL PORT - SPI TIMING

Inputs: Logic 0 = DGND, Logic 1 = VLC, CDOUT CL = 30 pF

Parameter	Symbol	Min	Max	Unit	
CCLK Clock Frequency	f_{sck}	0	100	MHz	
\overline{RST} Rising Edge to \overline{CS} Falling	t_{srs}	20	—	ns	
\overline{CS} Falling to CCLK Edge	t_{css}	20		μ s	
\overline{CS} High Time Between Transmissions	t_{csh}	1		ns	
CCLK Low Time	t_{scl}	66			
CCLK High Time	t_{sch}	66			
CDIN to CCLK Rising Setup Time	t_{dsu}	40			
CCLK Rising to DATA Hold Time (Note 1)	t_{dh}	15			
CCLK Falling to CDOUT Stable	t_{pd}			50	
Rise Time of CDOUT	t_{r1}			25	
Fall Time of CDOUT	t_{r1}	—			
Rise Time of CCLK and CDIN (Note 2)	t_{r2}		100		
Fall Time of CCLK and CDIN (Note 2)	t_{r2}				

Notes:

1. Data must be held for sufficient time to bridge the transition time of CCLK.
2. For $f_{sck} < 1$ MHz

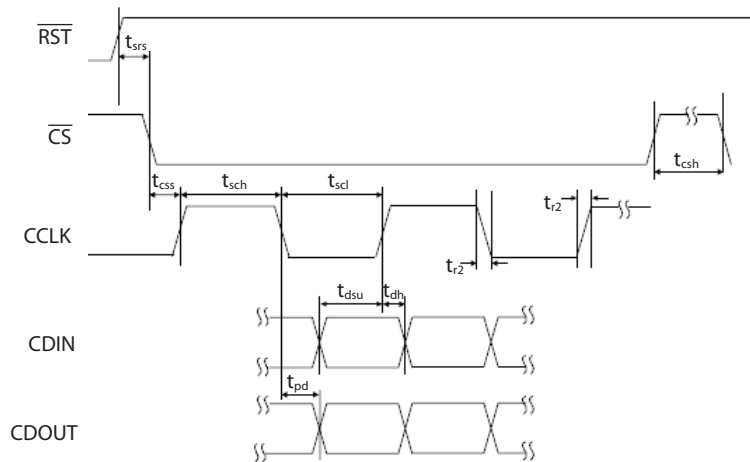

Figure 5. SPI Timing

4. APPLICATIONS

4.1 Power

The M8000 features five independent power pins that power various functional blocks within the device and allow for convenient interfacing to other devices. Table 1 shows what portion of the device is powered from each supply pin. Please refer to “Recommended Operating Conditions” on page 5 for the valid range of each power supply pin. The power supplied to each power pin can be independent of the power supplied to any other pin.

Power Supply Pin		
Pin Name	Pin Number	Functional Block
VA	4, 9	Analog Core
VX	20	Crystal Oscillator
VD	33	Digital Core
VLS	28	Serial Audio Interface
VLC	35	Control Logic

Table 1. Power Supply Pin Definitions

To meet full performance specifications, the M8000 requires normal low-noise board layout. The “Typical Connection Diagram” on page 33 shows the recommended power arrangements, with the VA pins connected to a clean supply. VD, which powers the digital filter, may be run from the system logic supply, or it may be powered from the analog supply via a single-pole decoupling filter.

Decoupling capacitors should be placed as near to the ADC as possible, with the lower value high-frequency capacitors placed nearest to the device leads. Clocks should be kept away from the FILT+ and VQ pins in order to avoid unwanted coupling of these signals into the device. The FILT+ and VQ decoupling capacitors must be positioned to minimize the electrical path to ground.

4.2 Control Port Mode and Stand-Alone Operation

4.2.1 Stand-Alone Mode

In Stand-Alone Mode, the M8000 is programmed exclusively with multi-use configuration pins. This mode provides a set of commonly used features, which comprise a subset of the complete set of device features offered in Control Port Mode.

To use the M8000 in Stand-Alone Mode, the configuration pins must be held in a stable state, at valid logic levels, and \overline{RST} must be asserted until the power supplies and clocks are stable and valid.

4.2.2 Control Port Mode

In Control Port Mode, all features of the M8000 are available. Four multi-use configuration pins become software pins that support the I²C or SPI bus protocol. To initiate Control Port Mode, a controller that supports I²C or SPI must be used to enable the internal register functionality. This is done by setting the CPEN bit (Bit 7 of the Global Control Port Register). Once CP-EN is set, all of the device configuration pins are ignored, and the internal register settings determine the operating modes of the part.

4.3 Master Clock Source

The M8000 requires a Master Clock that can come from one of two sources: an on-chip crystal oscillator driver or an externally generated clock.

4.3.1 On-Chip Crystal Oscillator Driver

When using the on-board crystal oscillator driver, the XTI pin (pin 21) is the input for the Master Clock (MCLK) to the device. The XTO pin (pin 22) must not be used to drive anything other than the oscillator tank circuitry. When using the on-board crystal driver, the topology shown in Figure 6 must be used. The crystal oscillator manufacturer supplies recommended capacitor values. A buffered copy of the XTI input is available as an output on the MCLK pin (pin 23), which is level-controlled by VLS and may be used to synchronize other parts to the device.

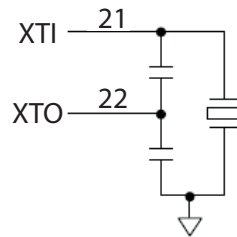

Figure 6. Crystal Oscillator Topology

4.3.2 Externally Generated Master Clock

If an external clock is used, the XTI and XTO pins must be grounded, and the MCLK pin becomes an input for the system master clock. The incoming MCLK should be at the logic level set by the user on the VLS supply pin.

4.4 Master and Slave Operation

The M8000 operation depends on two clocks that are synchronously derived from MCLK: SCLK and LRCK/FS.

The M8000 can operate as either clock master or clock slave with respect to SCLK and LRCK/FS. In Master Mode, the M8000 derives SCLK and LRCK/FS synchronously from MCLK and outputs the derived clocks on the SCLK pin (pin 25) and the LRCK/FS pin (pin 24), respectively. In Slave Mode, the SCLK and LRCK/FS are inputs, and the input signals must be synchronously derived from MCLK by a separate device such as another M8000 or a microcontroller. Figure 7 illustrates the clock flow of SCLK and LRCK/FS in both Master and Slave Modes.

The Master/Slave operation is controlled through the settings of M1 and M0 pins in Stand-Alone Mode or by the M[1] and M[0] bits in the Global Mode Control Register in Control Port Mode.



Figure 7. Master/Slave Clock Flow

4.4.1 Synchronization of Multiple Devices

To ensure synchronous sampling in applications where multiple ADCs are used, the MCLK and LRCK must be the same for all M8000 devices in the system. If only one master clock source is needed, one solution is to place one M8000 in Master Mode, and slave all of the other devices to the one master, as illustrated in Figure 8. If multiple master clock sources are needed, one solution is to supply all clocks from the same external source and time the M8000 reset de-assertion with the falling edge of MCLK. This will ensure that all converters begin sampling on the same clock edge.

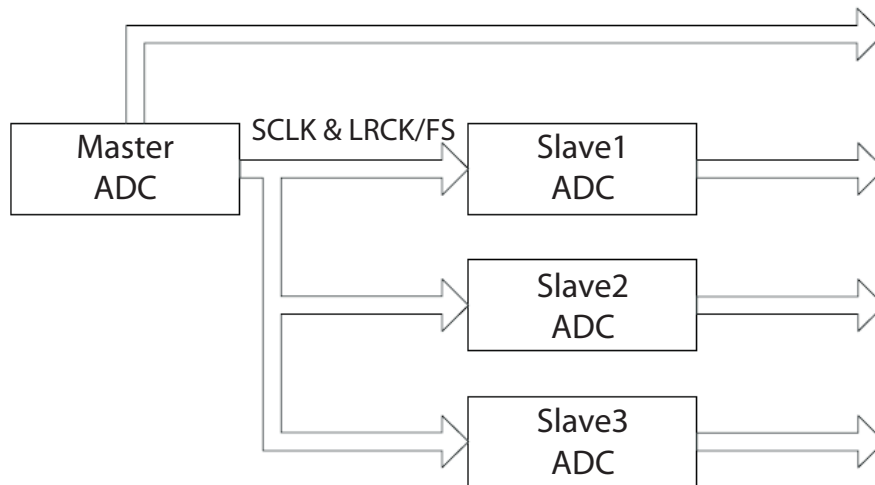

Figure 8. Master and Slave Clocking for a Multi-Channel Application

4.5 Serial Audio Interface (SAI) Format

The SAI port consists of two timing pins (SCLK, LRCK/FS) and four audio data output pins (SDOUT1/TDM, SDOUT2, SDOUT3/TMD and SDOUT4). The M8000 output is serial data in I²S, Left-Justified (LJ), or Time Division Multiplexed (TDM) digital audio interface formats. These formats are available to the user in both Stand-Alone Mode and Control Port Mode.

4.5.1 I²S and LJ Format

The I²S and LJ formats are both two-channel protocols. During one LRCK period, two channels of data are transmitted, odd channels first, then even. The MSB is always clocked out first.

In Slave Mode, the number of SCLK cycles per channel is fixed as described under “Serial Audio Interface - I²S/LJ Timing” on page 10. In Slave Mode, if more than 32 SCLK cycles per channel are received from a master controller, the M8000 will fill the longer frame with trailing zeros. If fewer than 24 SCLK cycles per channel are received from a master, the M8000 will truncate the serial data output to the number of SCLK cycles received.

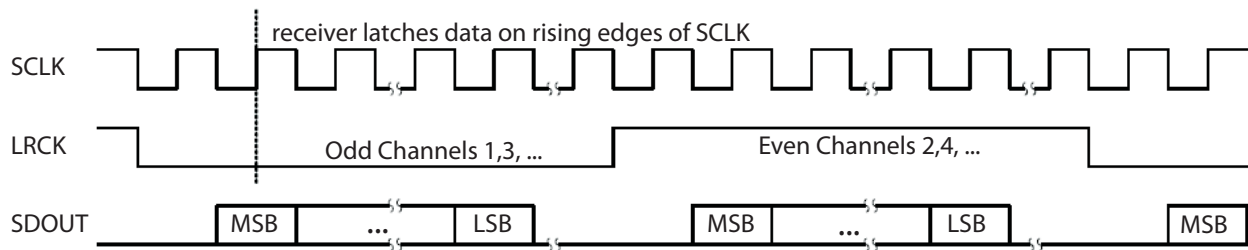

Figure 9. I²S Format

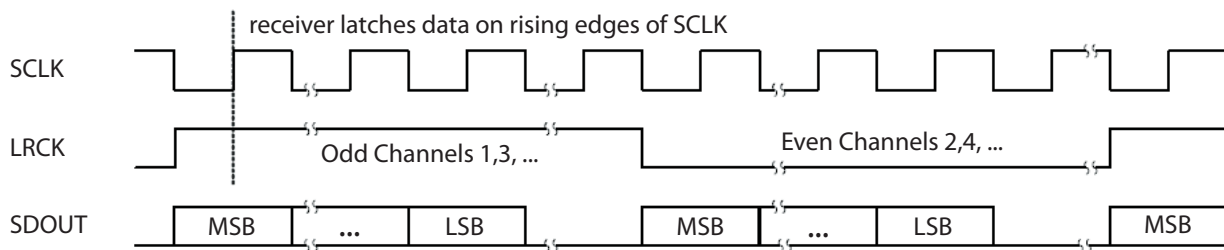

Figure 10. LJ Format

4.5.2 TDM Format

In TDM Mode, all eight channels of audio data are serially clocked out during a single Frame Sync (FS) cycle, as shown in Figure 11. The rising edge of FS signifies the start of a new TDM frame cycle. Each channel slot occupies 32 SCLK cycles, with the data left justified and with MSB first. TDM output data should be latched on the rising edge of SCLK within time specified under “Serial Audio Interface - TDM Timing” section on page 10. The TDM data output port resides on the SDOUT1 pin. The TDM output pin is complimentary TDM data. All SDOUT pins will remain active during TDM Mode. Refer to Section 4.11 “Optimizing Performance in TDM Mode” on page 22 for critical system design information.

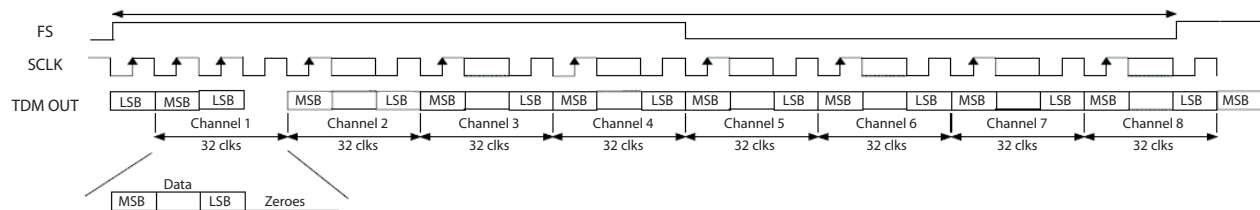

Figure 11. TDM Format

4.5.3 Configuring Serial Audio Interface Format

The serial audio interface format of the data is controlled by the configuration of the DIF1 and DIF0 pins in Stand-Alone Mode or by the DIF[1] and DIF[0] bits in the Global Mode Control Register in Control Port Mode, as shown in Table 2.

DIF1	DIF0	Mode
0	0	Left-Justified
0	1	I ² S
1	0	TDM
1	1	Reserved

Table 2. DIF1 and DIF0 Pin Settings

4.6 Speed Modes

4.6.1 Sample Rate Ranges

The M8000 supports sampling rates from 2 kHz to 216 kHz, divided into three ranges: 2 kHz - 54 kHz, 54 kHz - 108 kHz, and 108 kHz - 216 kHz. These sampling speed modes are called Single-Speed Mode (SSM), Double-Speed Mode (DSM), and Quad-Speed Mode (QSM), respectively.

4.6.2 Using M1 and M0 to Set Sampling Parameters

The Master/Slave operation and the sample rate range are controlled through the settings of the M1 and M0 pins in Stand-Alone Mode, or by the M[1] and M[0] bits in the Global Mode Control Register in Control Port Mode, as shown in Table 3.

M1	M0	Mode	Frequency
0	0	Single-Speed Master Mode (SSM)	2 kHz - 54 kHz
0	1	Double-Speed Master Mode (DSM)	54 kHz - 108 kHz
1	0	Quadruple-Speed Master Mode (QSM)	108 kHz - 216 kHz
1	1	Auto-Detected Speed Slave Mode	2 kHz - 216 kHz

Table 3. M1 and M0 Settings

4.6.3 Master Mode Clock Dividers

Figure 12 shows the configuration of the MCLK dividers and the sample rate dividers for Master Mode, including the significance of each MCLK divider pin (in Stand-Alone Mode) or bit (in Control Port Mode).

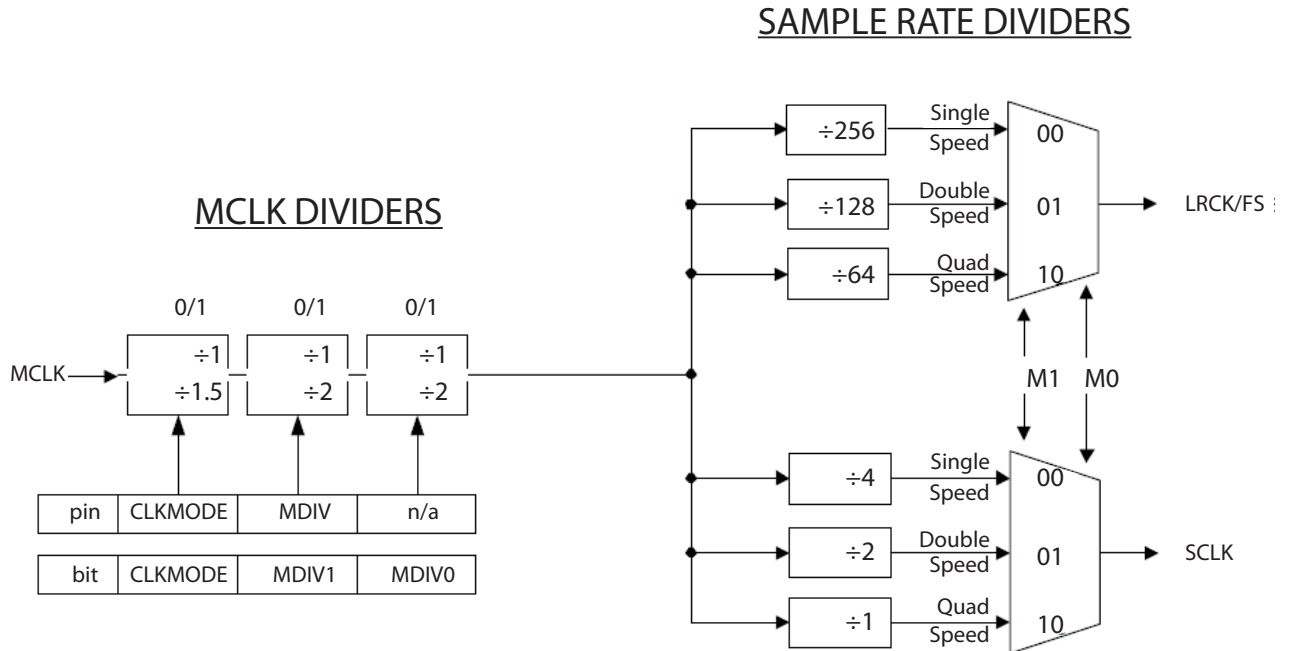

Figure 12. Master Mode Clock Dividers

4.6.4 Slave Mode Audio Clocking With Auto-Detect

In Slave Mode, the M8000 auto-detects speed mode, which eliminates the need to configure M1 and M0 when changing between speed modes. The external MCLK is subject to clock dividers as set by the clock divider pins in Stand-Alone Mode or the clock divider bits in Control Port Mode. The M8000 compares the divided down, internal MCLK to the incoming LRCK/FS and sets the speed mode based on the MCLK/LRCK ratio as shown in Figure 13.

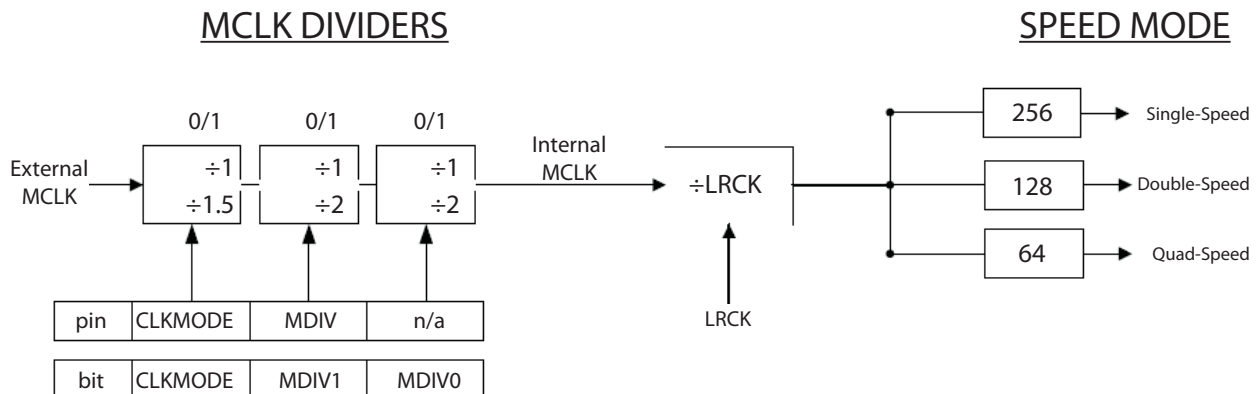

Figure 13. Slave Mode Auto-Detect Speed

4.7 Master and Slave Clock Frequencies

Tables 4 through 12 show the clock speeds for sample rates of 48 kHz, 96 kHz and 192 kHz. The MCLK/LRCK ratio should be kept at a constant value during each mode. In Master Mode, the device outputs the frequencies shown. In Slave Mode, the SCLK/LRCK ratio can be set according to design preference. However, device performance is guaranteed only when using the ratios shown in the tables.

LJ/I ² S MASTER OR SLAVE	SSM F _s = 48 kHz				
MCLK Divider	÷4	÷3	÷2	÷1.5	÷1
MCLK (MHz)	49.152	36.864	24.576	18.384	12.288
SCLK (MHz)	3.072	3.072	3.072	3.072	3.072
MCLK/LRCK Ratio	1024	768	512	384	256
SCLK/LRCK Ratio	64	64	64	64	64

Table 4. Frequencies for 48 kHz Sample Rate using LJ/I²S

LJ/I ² S MASTER OR SLAVE	DSM F _s = 96 kHz				
MCLK Divider	÷4	÷3	÷2	÷1.5	÷1
MCLK (MHz)	49.152	36.864	24.576	18.384	12.288
SCLK (MHz)	6.144	6.144	6.144	6.144	6.144
MCLK/LRCK Ratio	512	384	256	192	128
SCLK/LRCK Ratio	64	64	64	64	64

Table 5. Frequencies for 96 kHz Sample Rate using LJ/I²S

LJ/I ² S MASTER OR SLAVE	QSM F _s = 192 kHz				
MCLK Divider	÷4	÷3	÷2	÷1.5	÷1
MCLK (MHz)	49.152	36.864	24	18.384	12.288
SCLK (MHz)	12.288	12.288	12.288	12.288	12.288
MCLK/LRCK Ratio	256	192	128	96	64
SCLK/LRCK Ratio	64	64	64	64	64

Table 6. Frequencies for 192 kHz Sample Rate using LJ/I²S

TDM MASTER	SSM F _s = 48 kHz				
MCLK Divider	÷4	÷3	÷2	÷1.5	÷1
MCLK (MHz)	49.152	36.864	24.567	18.384	12.288
SCLK (MHz)	12.288	12.288	12.288	12.288	12.288
MCLK/FS Ratio	1024	768	512	384	256
SCLK/FS Ratio	256	256	256	256	256

Table 7. Frequencies for 48 kHz Sample Rate using TDM

TDM SLAVE	SSM F _s = 48 kHz				
MCLK Divider	÷4	÷3	÷2	÷1.5	÷1
MCLK (MHz)	49.152	36.864	24.567	18.384	12.288
SCLK (MHz)	12.288	12.288	12.288	12.288	12.288
MCLK/FS Ratio	1024	768	512	384	256
SCLK/FS Ratio	256	256	256	256	256

Table 8. Frequencies for 48 kHz Sample Rate using TDM

TDM MASTER	DSM F _s = 96 kHz				
MCLK Divider	÷4	÷3	÷2	—	—
MCLK (MHz)	49.152	36.864	24.567	—	—
SCLK (MHz)	24.576	24.576	24.576	—	—
MCLK/FS Ratio	512	384	256	—	—
SCLK/FS Ratio	256	256	256	—	—

Table 9. Frequencies for 96 kHz Sample Rate using TDM

TDM SLAVE	DSM F _s = 96 kHz				
MCLK Divider	÷4	÷3	÷2	÷1.5	÷1
MCLK (MHz)	49.152	36.864	24.567	18.384	12.288
SCLK (MHz)	24.576	24.576	24.576	24.576	24.576
MCLK/FS Ratio	512	384	256	192	128
SCLK/FS Ratio	256	256	256	256	256

Table 10. Frequencies for 96 kHz Sample Rate using TDM

TDM MASTER	QSM F _s = 192 kHz				
MCLK Divider	÷4	—	—	—	—
MCLK (MHz)	49.152	—	—	—	—
SCLK (MHz)	49.152	—	—	—	—
MCLK/FS Ratio	256	—	—	—	—
SCLK/FS Ratio	256	—	—	—	—

Table 11. Frequencies for 192 kHz Sample Rate using TDM

TDM SLAVE	QSM F _s = 192 kHz				
MCLK Divider	÷4	÷3	÷2	÷1.5	÷1
MCLK (MHz)	49.152	36.864	24.567	18.384	12.288
SCLK (MHz)	49.152	49.152	49.152	49.152	49.152
MCLK/FS Ratio	256	192	128	96	64
SCLK/FS Ratio	256	256	256	256	256

Table 12. Frequencies for 192 kHz Sample Rate using TDM

4.8 Reset

The device should be held in reset until power is applied and all incoming clocks are stable and valid. Upon de-assertion of \overline{RST} , the state of the configuration pins is latched, the state machine begins, and the device starts sending audio output data a maximum of 524288 MCLK cycles after the release of \overline{RST} . When changing between mode configurations in Stand-Alone Mode, including clock dividers, serial audio interface format, master/slave, or speed modes, it is recommended to reset the device following the change by holding the \overline{RST} pin low for a minimum of one MCLK cycle and then restoring the pin to a logic-high condition.

4.8.1 Power-Down Mode

The M8000 features a Power-Down Mode in which power is temporarily withheld from the modulators, the crystal oscillator driver, the digital core, and the serial port. The user can access Power-Down Mode by holding the device in reset and holding all clock lines at a static, valid logic level (either logic-high or logic-low). “DC Power” on page 6 shows the power-saving associated with Power-Down Mode.

4.9 Overflow Detection

4.9.1 Overflow in Stand-Alone Mode

The M8000 includes overflow detection on all input channels. In Stand-Alone Mode, this information is presented as open drain, active low on the \overline{OVFL} pin. The pin will go to a logical low as soon as an over range condition in any channel is detected. The data will remain low, then time-out as specified in Section “Overflow Timeout” on page 8. After the time-out, the \overline{OVFL} pin will return to a logical high if there has not been any other over-range condition detected. Note that an over-range condition on any channel will restart the time-out period.

4.9.2 Overflow in Control Port Mode

In Control Port Mode, the Overflow Status Register interacts with the Overflow Mask Register to provide interrupt capability for each individual channel. See Section 5.4 “02h (OVFL) Overflow Status Register” on page 27 for details on these two registers.

4.10 Analog Connections

The analog modulator samples the input at half of the internal Master Clock frequency, or 6.144 MHz nominally. The digital filter will reject signals within the stop band of the filter. However, there is no rejection of input signals that are at $(N \times 6.144 \text{ MHz})$ the digital pass band frequency, where $n=0,1,2,\dots$. Refer to Figure 14, which shows the suggested filter that will attenuate any noise energy at 6.144 MHz in addition to providing the optimum source impedance for the modulators. The use of capacitors that have a large voltage coefficient (such as general-purpose ceramics) must be avoided since these can degrade signal linearity. COG capacitors are recommended for this application.

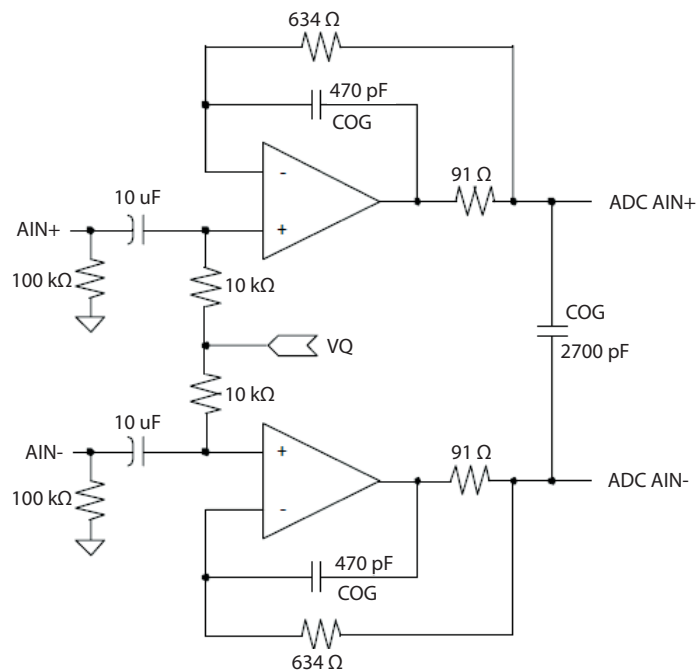

Figure 14. Recommended Analog Input Buffer

4.11 Optimizing Performance in TDM Mode

Noise Management is a design technique that is utilized in the majority of audio A/D converters. Noise management is relatively simple conceptually. The goal of noise management is to interleave the on-chip digital activity with the analog sampling processes to ensure that the noise generated by the digital activity is minimized (ideally non-existent) when the analog sampling occurs. Noise management, when implemented properly, minimizes the on-chip interference between the analog and digital sections of the device. This technique has proven to be very effective and has simplified the process of implementing an A/D converter into a systems design. The dominant source of interference (and most difficult to control) is the activity on the serial audio interface (SAI). However, noise management becomes more difficult to implement as audio sample rates increase simply due to the fact that there is less time between transitions on the SAI.

The M8000 A/D converter supports a multi-channel Time-Division-Multiplexed interface for Single, Double and Quad-Speed sampling modes. In Single-Speed Mode, sample rates below 50 kHz, the required frequencies of the audio serial ports are sufficiently low that it is possible to implement noise-management. In this mode, the performance of the device is relatively immune to activity on the audio ports.

However, in Double-Speed and Quad-Speed modes there is insufficient time to implement noise management due to the required frequencies of the audio ports. Therefore, analog performance, both dynamic range and THD+N, can be degraded if the serial port transitions occur concurrently with the analog sampling. The magnitude of the interference is not only related to the timing of the transition but also the di/dt or transient currents associated with the activity on the serial ports. Even though there is insufficient time to properly implement noise management, the interference effects can be minimized by controlling the transient currents required of the serial ports in Double and Quad-Speed TDM Modes.

In addition to standard mixed-signal design techniques, system performance can be maximized by following several guidelines during design.

- Operate the serial audio port at 3.3 V and not 5 V. The lower serial port voltage lowers transient currents.
- Operate the A/D converter as a system clock Slave. The serial clock and Left/Right clock become high-impedance inputs in this mode and do not generate significant transient currents.
- Place a buffer on the serial data output very near the A/D converter. Minimizing the stray capacitance of the printed circuit board trace and the loading presented by other devices on the serial data line will minimize the transient current.
- Place a resistor, near the converter, between the A/D serial data output and the buffer. This resistor will reduce the instantaneous switching currents into the capacitive loads on the nets, resulting in a slower edge rate. The value of the resistor should be as high as possible without causing timing problems elsewhere in the system.

4.12 DC Offset Control

The M8000 includes a dedicated high-pass filter for each channel to remove input DC offset at the system level. A DC level may result in audible “clicks” when switching between devices in a multi-channel system.

In Stand-Alone Mode, all of the high-pass filters remain enabled. In Control Port Mode, the high-pass filters default to enabled, but may be controlled by writing to the *HPF* register. If any *HPF* bit is taken low, the respective high-pass filter is enabled, and it continuously subtracts a measure of the DC offset from the output of the decimation filter. If any *HPF* bit is taken high during device operation, the value of the DC offset register is frozen, and this DC offset will continue to be subtracted from the conversion result.

4.13 Control Port Operation

The Control Port is used to read and write the internal device registers. It supports two industry standard formats, I²C and SPI. The part is in I²C format by default. SPI Mode is selected if there is ever a high-to-low transition on the *ADO/CS* pin after the *RST* pin has been restored high.

In Control Port Mode, all features of the M8000 are available. Four multi-use configuration pins become software pins that support the I²C or SPI bus protocol. To initiate Control Port Mode, a controller that supports I²C or SPI must be used to enable the internal register functionality. This is done by setting the CP-EN bit (Bit 7 of the Global Control Port Register). Once CP-EN is set, all of the device configuration pins are ignored, and the internal register settings determine the operating modes of the part.

4.13.1 SPI Mode

In SPI Mode, CS is the M8000 chip select signal; CCLK is the control port bit clock (input into the M8000 from a controller); CDIN is the input data line from a controller; CDOUT is the output data line to a controller. Data is clocked in on the rising edge of CCLK and is supplied on the falling edge of CCLK.

To write to a register, bring CS low. The first seven bits on CDIN form the chip address and must be 1001111. The eighth bit is a read/write indicator (R/W), which should be low to write. The next eight bits form the Memory Address Pointer (MAP), which is set to the address of the register that is to be updated. The next eight bits are the data that will be placed into the register designated by the MAP. During writes, the CDOUT output stays in the Hi-Z state. It may be externally pulled high or low with a 47 kΩ resistor, if desired.

There is a MAP auto-increment capability, which is enabled by the INCR bit in the MAP register. If INCR is a zero, the MAP will stay constant for successive read or writes. If INCR is set to a 1, the MAP will auto-increment after each byte is read or written, allowing block reads or writes of successive registers.

To read a register, the MAP has to be set to the correct address by executing a partial write cycle that finishes (CS high) immediately after the MAP byte. The MAP auto-increment bit (INCR) may be set or not, as desired. To begin a read, bring CS low, send out the chip address and set the read/write bit (R/) high. The next falling edge of CCLK will clock out the MSB of the addressed register (CDOUT will leave the high impedance state). If the MAP autoincrement bit is set to 1, the data for successive registers will appear consecutively.

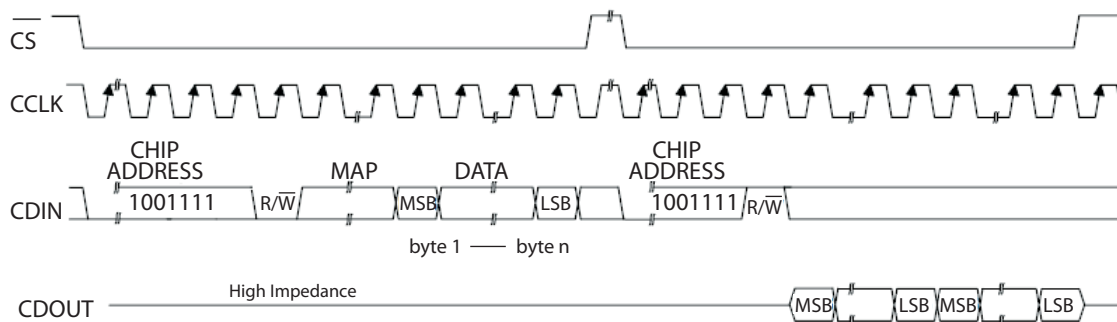

MAP = Memory Address Pointer, 8 bits, MSB first
Figure 15. SPI Format

4.13.2 I²C Mode

In I²C Mode, SDA is a bidirectional data line. Data is clocked into and out of the part by the clock, SCL.

There is no CS pin. Pins AD0 and AD1 form the two least-significant bits of the chip address and should be connected through a resistor to VLC or DGND, as desired. The state of the pins is latched when the M8000 is being released from RST.

A Start condition is defined as a falling transition of SDA while SCL is high. A Stop condition is a rising transition of SDA while SCL is high. All other transitions of SDA occur while SCL is low. The first byte sent to the M8000 after a Start condition consists of a 7-bit chip address field and a R/W bit (high for a read, low for a write). The upper five bits of the 7-bit address field are fixed at 10011. To communicate with a M8000, the chip address field, which is the first byte sent to the M8000, should match 10011 and be followed by the settings of the AD1 and AD0. The eighth bit of the address is the R/W bit. If the operation is a write, the next byte is the Memory Address Pointer (MAP), which selects the register to be read or written. If the operation is a read, the contents of the register pointed to by the MAP will be output. Setting the auto-increment bit in MAP allows successive reads or writes of consecutive registers. Each byte is separated by an acknowledge bit. The ACK bit is output from the M8000 after each input byte is read and is input to the M8000 from the microcontroller after each transmitted byte.

Since the read operation cannot set the MAP, an aborted write operation is used as a preamble. The write operation is aborted after the acknowledgement for the MAP byte by sending a stop condition. The following pseudo code illustrates an aborted write operation followed by a read operation.

- Send start condition.
- Send 1001xx0 (chip address & write operation).
- Receive acknowledge bit.
- Send MAP byte, auto increment off.
- Receive acknowledge bit.
- Send stop condition, aborting write.
- Send start condition.
- Send 1001xx1 (chip address & read operation).
- Receive acknowledge bit.
- Receive byte, contents of selected register.
- Send acknowledge bit.
- Send stop condition.

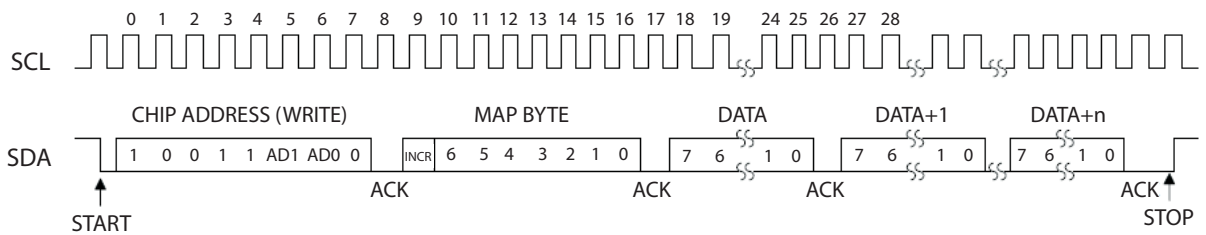

Figure 16. I²C Write Format

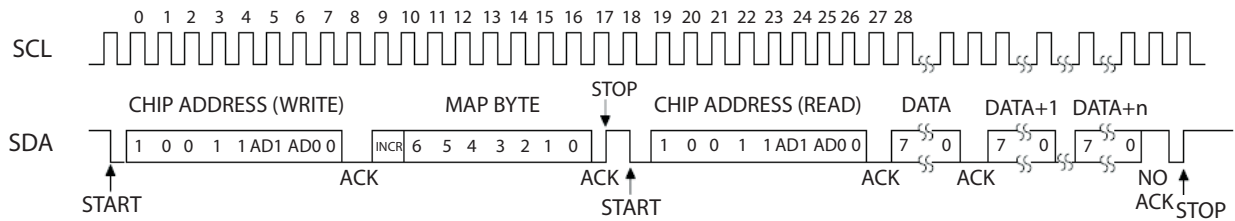

Figure 17. I²C Read Format

5. REGISTER MAP

In Control Port Mode, the bits in these registers are used to control all of the programmable features of the ADC. All registers above 0 Ah are RESERVED.

5.1 Register Quick Reference

Adr	Name	7	6	5	4	3	2	1	0
00	REVI	CHIP-ID [3:0]				REVISION [3:0]			
01	GCTL	CP-EN	CLKMODE	MDIV [1:0]		DIF [1:0]		MODE [1:0]	
02	OVFL	$\overline{\text{OVFL}}_8$	$\overline{\text{OVFL}}_7$	$\overline{\text{OVFL}}_6$	$\overline{\text{OVFL}}_5$	$\overline{\text{OVFL}}_4$	$\overline{\text{OVFL}}_3$	$\overline{\text{OVFL}}_2$	$\overline{\text{OVFL}}_1$
03	OVFM	OVFM8	OVFM7	OVFM6	OVFM5	OVFM4	OVFM3	OVFM2	OVFM1
04	HPF	$\overline{\text{HPF}}_8$	$\overline{\text{HPF}}_7$	$\overline{\text{HPF}}_6$	$\overline{\text{HPF}}_5$	$\overline{\text{HPF}}_4$	$\overline{\text{HPF}}_3$	$\overline{\text{HPF}}_2$	$\overline{\text{HPF}}_1$
05	RESERVED	—	—	—	—	—	—	—	—
06	PDNE	RESERVED		PDN-BG	PDN-OSC	PDN87	PDN65	PDN43	PDN21
07	RESERVED	—	—	—	—	—	—	—	—
08	MUTE	MUTE8	MUTE7	MUTE6	MUTE5	MUTE4	MUTE3	MUTE2	MUTE1
09	RESERVED	—	—	—	—	—	—	—	—
0A	SDEN	RESERVED				$\overline{\text{SDEN}}_4$	$\overline{\text{SDEN}}_3$	$\overline{\text{SDEN}}_2$	$\overline{\text{SDEN}}_1$

5.2 00h (REVI) Chip ID Code & Revision Register

R/W	7	6	5	4	3	2	1	0
R	CHIP-ID [3:0]				REVISION [3:0]			

Default: See description

The Chip ID Code & Revision Register is used to store the ID and revision of the chip.

Bits[7:4] contain the chip ID, where the M8000 is represented with a value of 0x8.

Bits[3:0] contain the revision of the chip, where revision A is represented as 0x0, revision B is represented as 0x1, etc.

5.3 01h (GCTL) Global Mode Control Register

R/W	7	6	5	4	3	2	1	0
R/W	CP-EN	CLKMODE	MDIV [1:0]		DIF [1:0]		MODE [1:0]	

Default: 0x00

The Global Mode Control Register is used to control the Master/Slave Speed modes, the serial audio data format and the Master clock dividers for all channels. It also contains a Control Port enable bit.

Bit[7] CP-EN manages the Control Port Mode. Until this bit is asserted, all pins behave as if in Stand-Alone Mode. When this bit is asserted, all pins used in Stand-Alone Mode are ignored, and the corresponding register values become functional.

Bit[6] CLKMODE Setting this bit puts the part in 384X mode (divides XTI by 1.5), and clearing the bit invokes 256X mode (divide XTI by 1.0 - pass through).

Bits[5:4] MDIV[1:0] Each bit selects an XTI divider. When either bit is low, an XTI divide-by-1 function is selected. When either bit is HIGH, an XTI divide-by-2 function is selected. With both bits HIGH, XTI is divided by 4.

The table below shows the composite XTI division using both CLKMODE and MDIV[1:0].

CLKMODE,MDIV[1],MDIV[0]	DESCRIPTION
0	Divide-by-1
100	Divide-by-1.5
001 or 010	Divide-by-2
101 or 110	Divide-by-3
11	Divide-by-4
111	Reserved

Bits[3:2] DIF[1:0] Determine which data format the serial audio interface is using to clock-out data.

DIF[1:0]

0x00 Left-Justified format

0x01 I²S format

0x02 TDM

0x03 Reserved

Bits[1:0] MODE[1:0] This bit field determines the device sample rate range and whether it is operating as an audio clocking Master or Slave.

MODE[1:0]

0x00 Single-Speed Mode Master

0x01 Double-Speed Mode Master

0x02 Quad-Speed Mode Master

0x03 Slave Mode all speeds

5.4 02h (OVFL) Overflow Status Register

R/W	7	6	5	4	3	2	1	0
R	<u>OVFL8</u>	<u>OVFL7</u>	<u>OVFL6</u>	<u>OVFL5</u>	<u>OVFL4</u>	<u>OVFL3</u>	<u>OVFL2</u>	<u>OVFL1</u>

Default: 0xFF, no overflows have occurred.

Note: This register interacts with Register 03h, the Overflow Mask Register.

The Overflow Status Register is used to indicate an individual overflow in a channel. If an overflow condition on any channel is detected, the corresponding bit in this register is asserted (low) in addition to the open drain active low OVFL pin going low. Each overflow status bit is sticky and is cleared only when read, providing full interrupt capability.

5.5 03h (OVFM) Overflow Mask Register

R/W	7	6	5	4	3	2	1	0
R/W	OVFM8	OVFM7	OVFM6	OVFM5	OVFM4	OVFM3	OVFM2	OVFM1

Default: 0xFF, all overflow interrupts enabled.

The Overflow Mask Register is used to allow or prevent individual channel overflow events from creating activity on the OVFL pin. When a particular bit is set low in the Mask register, the corresponding overflow bit in the Overflow Status register is prevented from causing any activity on the OVFL pin.

5.6 04h (\overline{HPF}) High-Pass Filter Register

R/W	7	6	5	4	3	2	1	0
R/W	$\overline{HPF8}$	$\overline{HPF7}$	$\overline{HPF6}$	$\overline{HPF5}$	$\overline{HPF4}$	$\overline{HPF3}$	$\overline{HPF2}$	$\overline{HPF1}$

Default: 0x00, all high-pass filters enabled.

The High-Pass Filter Register is used to enable or disable a high-pass filter that exists for each channel. These filters are used to perform DC offset calibration, a procedure that is detailed in “DC Offset Control” on page 23.

5.7 05h Reserved

R/W	7	6	5	4	3	2	1	0
RESERVED	—	—	—	—	—	—	—	—

5.8 06h (PDN) Power Down Register

R/W	7	6	5	4	3	2	1	0
R/W	RESERVED		PDN-BG	PDN-OSC	PDN87	PDN65	PDN43	PDN21

Default: 0x00 - everything powered up

The Power Down Register is used as needed to reduce the chip’s power consumption.

Bit[7] RESERVED

Bit[6] RESERVED

Bit[5] PDN-BG When set, this bit powers-down the band gap reference.

Bit[4] PDN-OSC controls power to the internal oscillator core. When asserted, the internal oscillator core is shut down, and no clock is supplied to the chip. If the chip is running off an externally supplied clock at the MCLK pin, it is also prevented from clocking the device internally.

Bit[3:0] PDN When any bit is set, all clocks going to a channel pair are turned off, and the serial data outputs are forced to all zeroes.

5.9 07h Reserved

R/W	7	6	5	4	3	2	1	0
RESERVED	—	—	—	—	—	—	—	—

5.10 08h (MUTE) Mute Control Register

R/W	7	6	5	4	3	2	1	0
R/W	MUTE8	MUTE7	MUTE6	MUTE5	MUTE4	MUTE3	MUTE2	MUTE1

Default: 0x00, no channels are muted.

The Mute Control Register is used to mute or unmute the serial audio data output of individual channels. When a bit is set, that channel’s serial data is muted by forcing the output to all zeroes.

5.11 09h Reserved

R/W	7	6	5	4	3	2	1	0
RESERVED	—	—	—	—	—	—	—	—

5.12 0Ah (SDEN) SDOUT Enable Control Register

R/W	7	6	5	4	3	2	1	0
R/W	RESERVED				SDEN4	SDEN3	SDEN2	SDEN1

Default: 0x00, all SDOUT pins enabled.

The SDOUT Enable Control Register is used to tri-state the serial audio data output pins. Each bit, when set, tri-states the associated SDOUT pin.

6. FILTER PLOTS

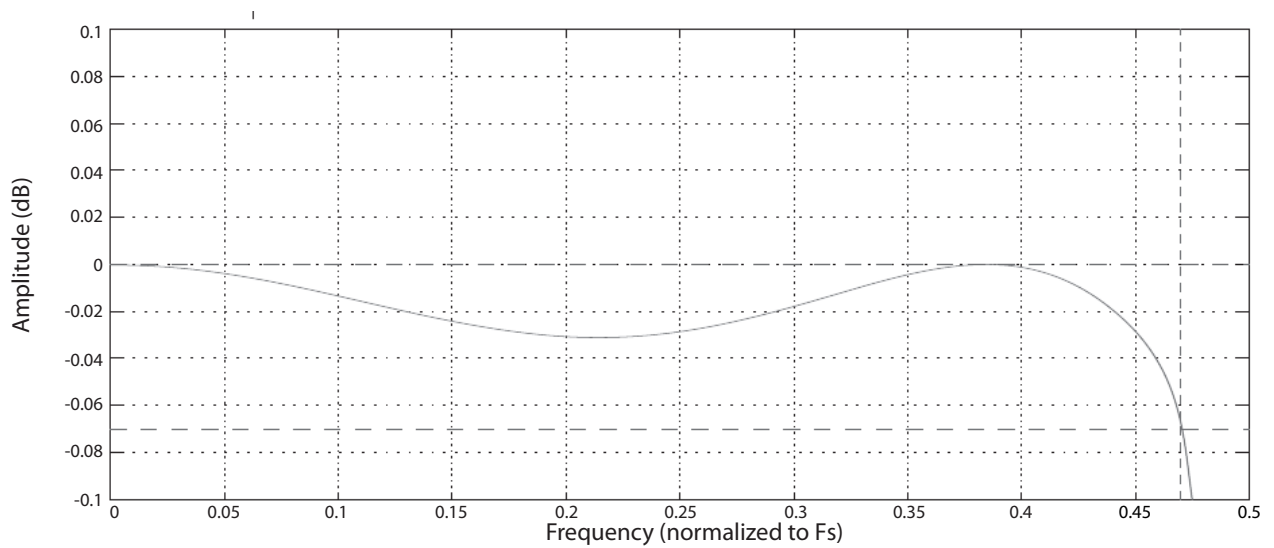

Figure 18. SSM Pass band

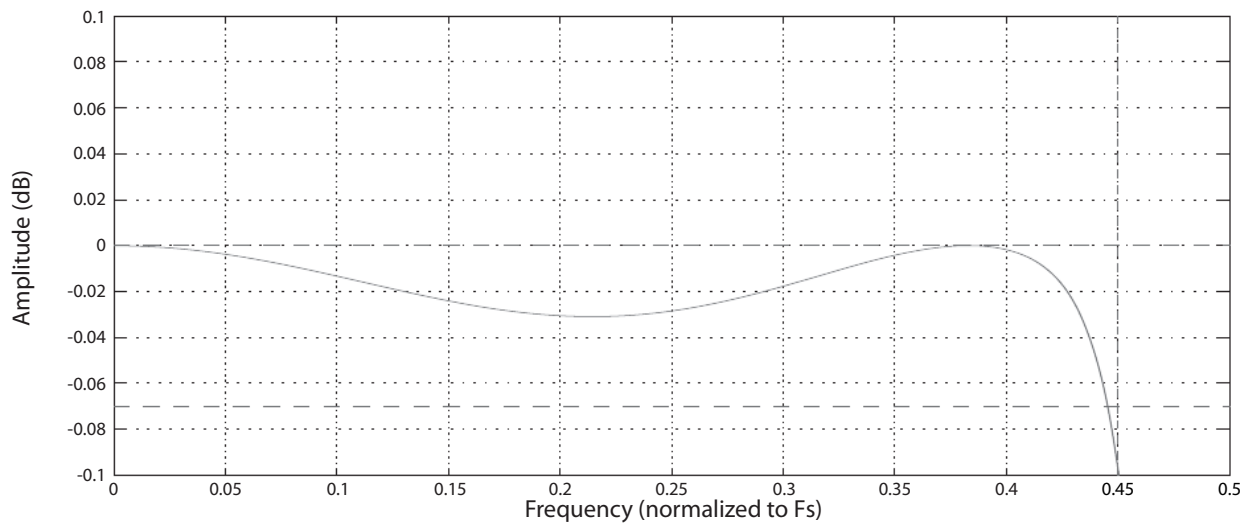

Figure 19. DSM Pass band

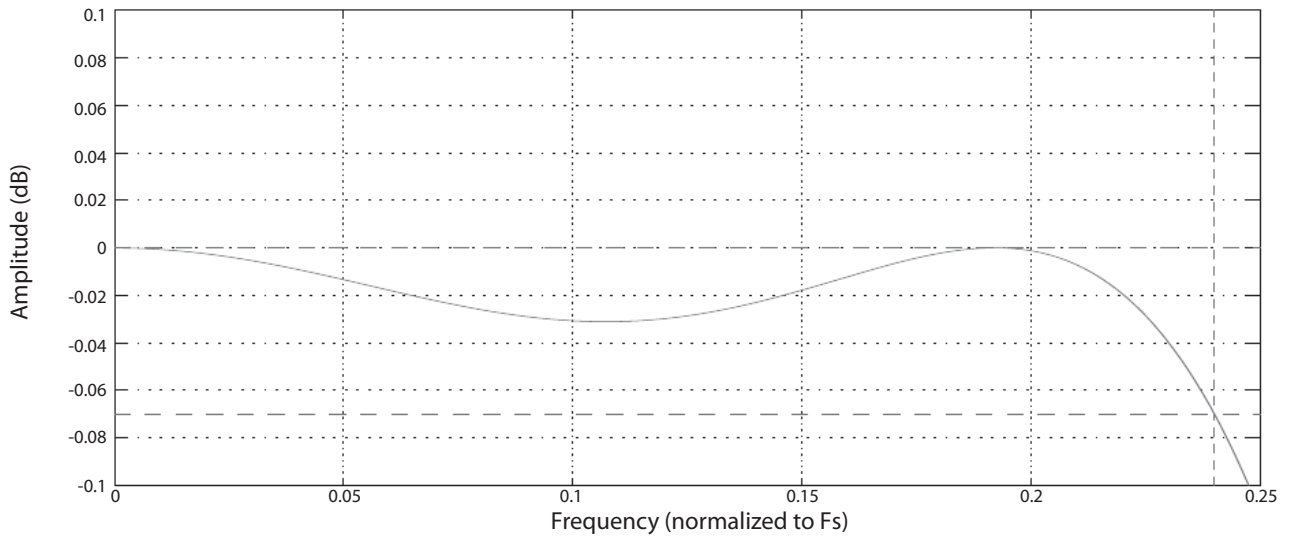

Figure 20. QSM Pass band

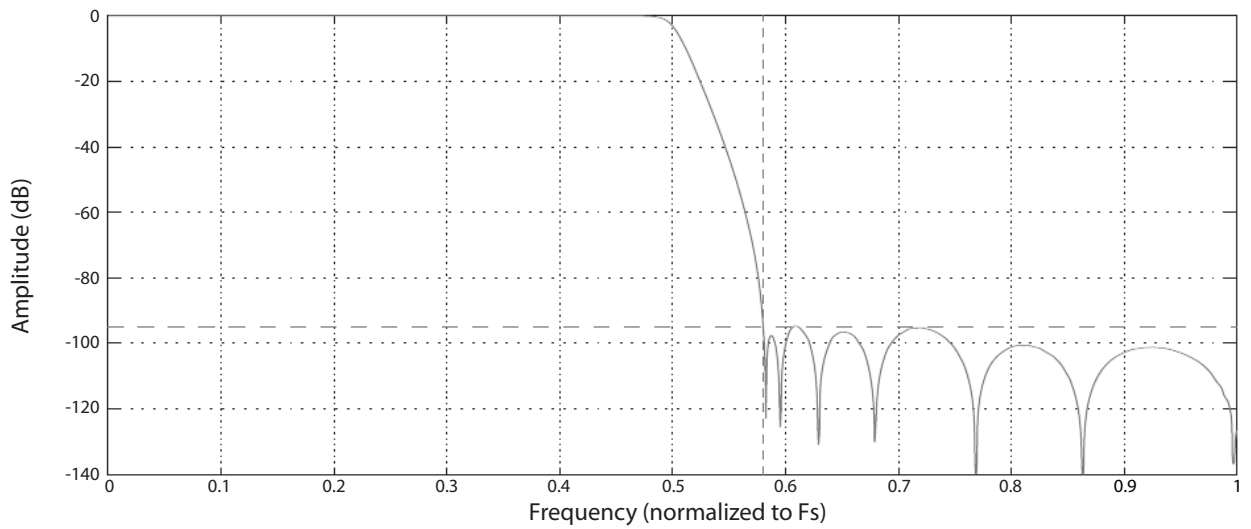

Figure 21. SSM Stop band

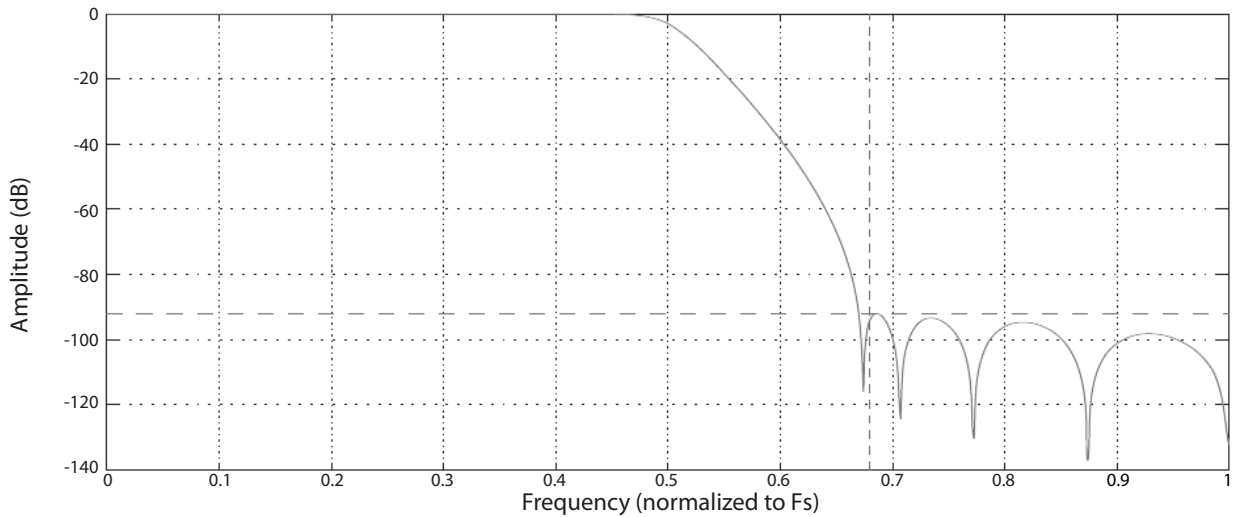

Figure 22. DSM Stop band

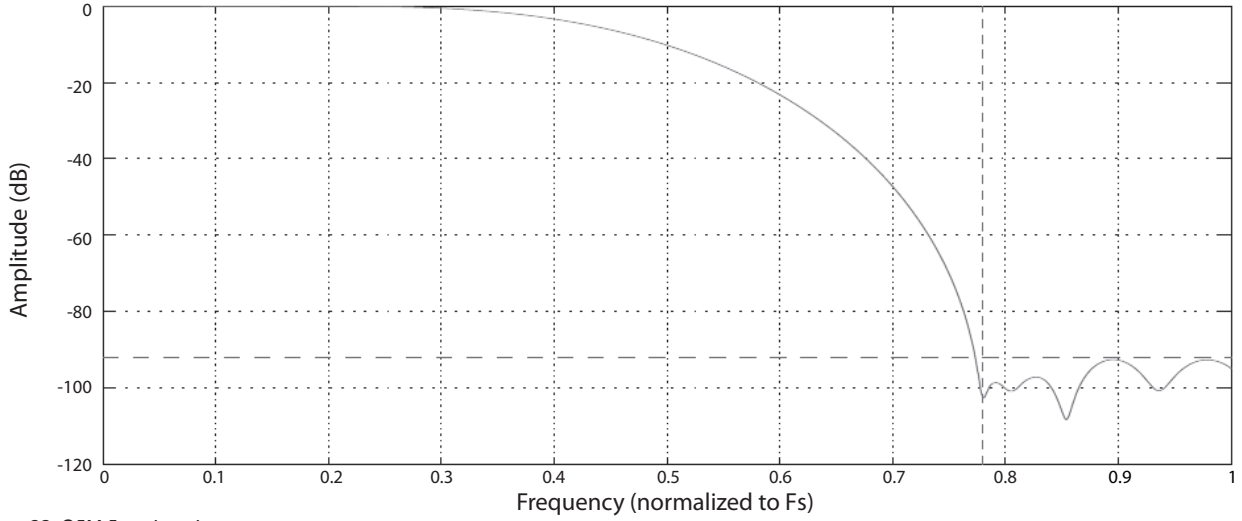

Figure 23. QSM Stop band

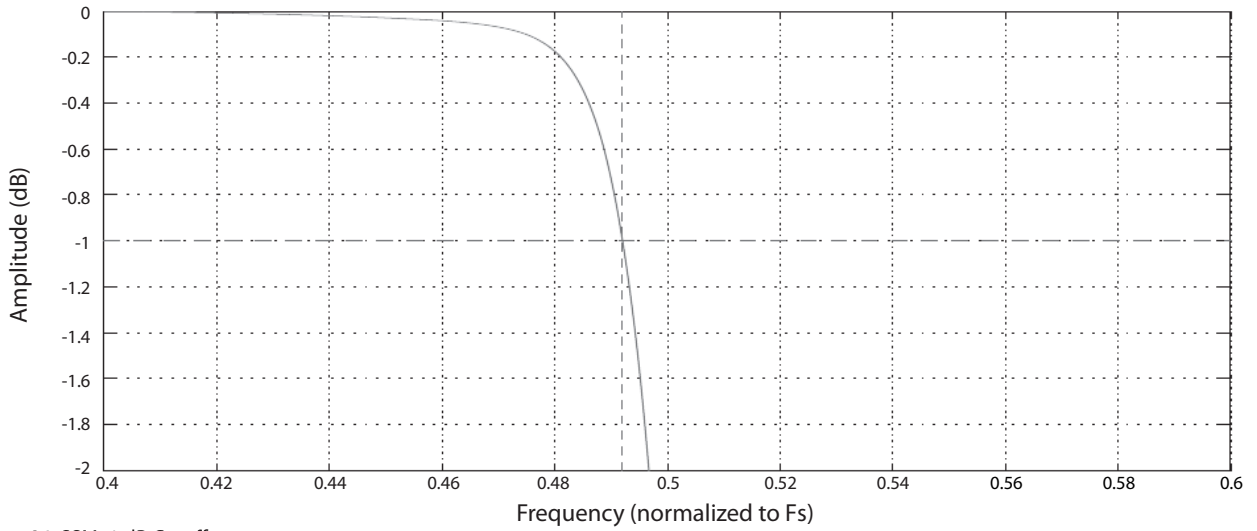

Figure 24. SSM -1 dB Cutoff

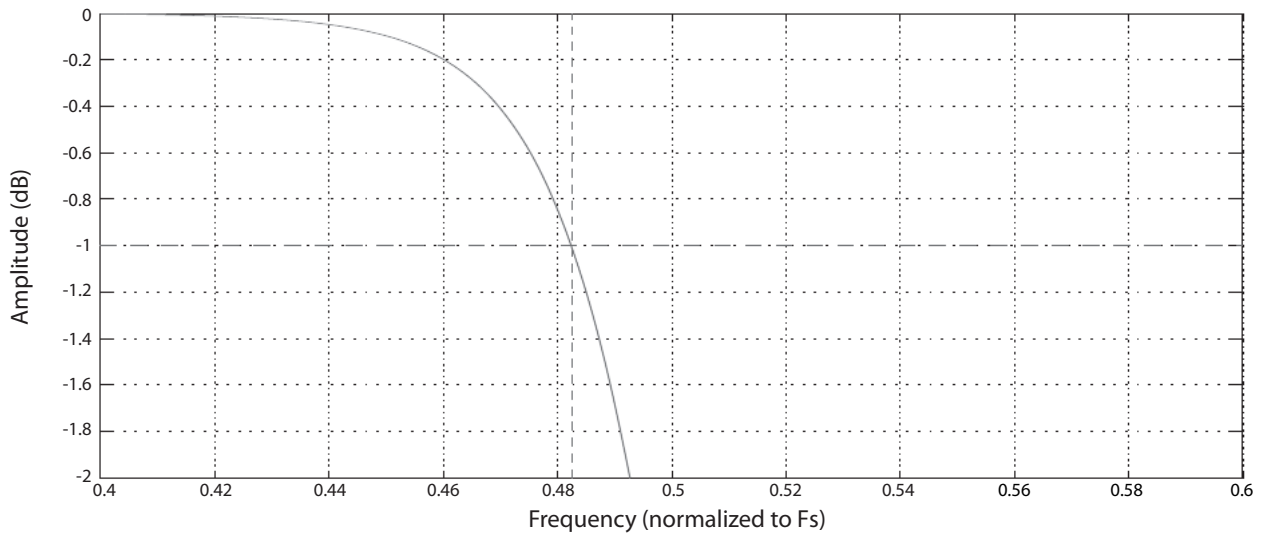

Figure 25. DSM -1 dB Cutoff

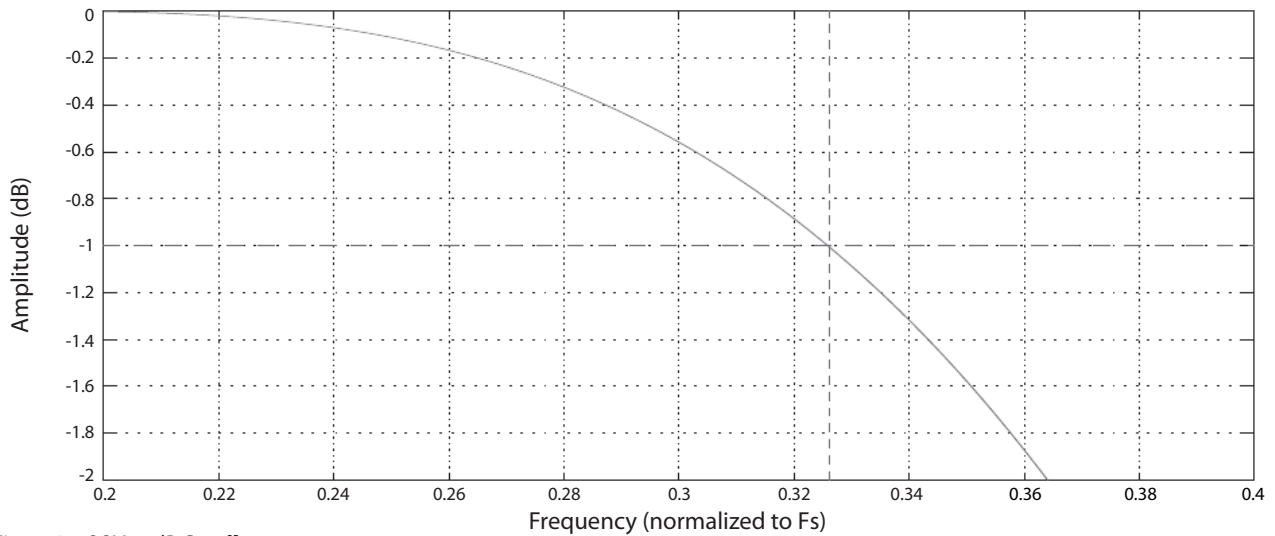

Figure 26. QSM -1 dB Cutoff

7. PARAMETER DEFINITIONS

Dynamic Range

The ratio of the rms value of the signal to the rms sum of all other spectral components over the specified bandwidth. Dynamic Range is a signal-to-noise ratio measurement over the specified bandwidth made with a -60 dBFS signal. 60 dB is added to resulting measurement to refer the measurement to full scale. This technique ensures that the distortion components are below the noise level and do not affect the measurement. This measurement technique has been accepted by the Audio Engineering Society, AES17-199, and the Electronic Industries Association of Japan, EIAJ CP-307. Expressed in decibels. The dynamic range is specified with and without an A-weighting filter.

Total Harmonic Distortion + Noise

The ratio of the rms value of the signal to the rms sum of all other spectral components over the specified bandwidth (typically 10 Hz to 20 kHz), including distortion components. Expressed in decibels. Measured at -1 and -20 dBFS as suggested in AES17-1991 Annex A. Specified using an A-weighting filter.

Frequency Response

A measure of the amplitude response variation from 10 Hz to 20 kHz relative to the amplitude response at 1 kHz. Units in decibels.

Interchannel Isolation

A measure of crosstalk between one channel and all remaining channels, measured for each channel at the converter's output with no signal to the input under test and a full-scale signal applied to all other channels. Units in decibels.

Interchannel Gain Mismatch

The gain difference between left and right channels. Units in decibels.

Gain Error

The deviation from the nominal full-scale analog output for a full-scale digital input.

Gain Drift

The change in gain value with temperature. Units in ppm/°C.

Offset Error

The deviation of the mid-scale transition (111...111 to 000...000) from the ideal. Units in mV.

Intra-Channel Phase Deviation

The deviation from linear phase within a given channel.

Inter-Channel Phase Deviation

The difference in phase response between channels.

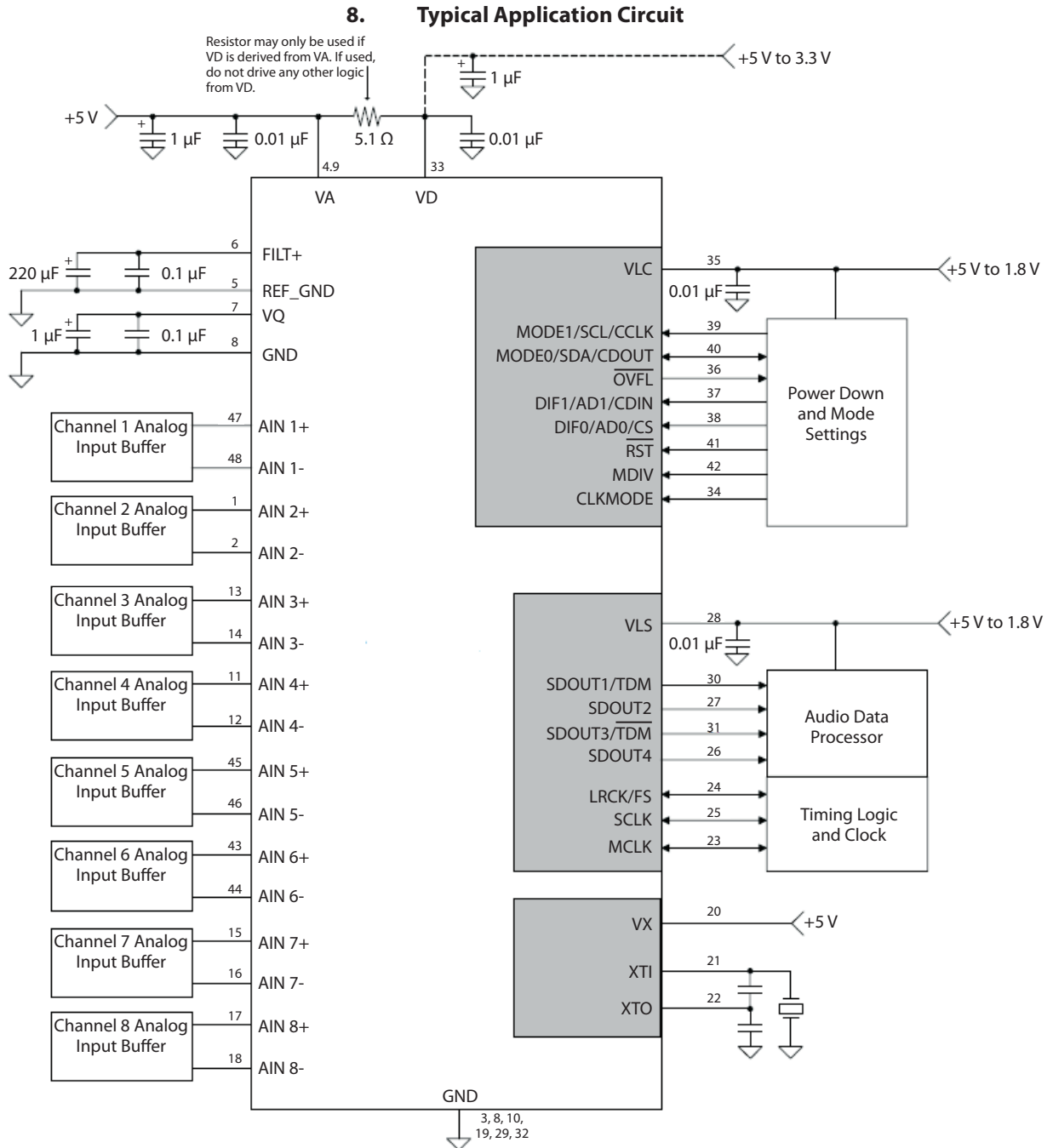
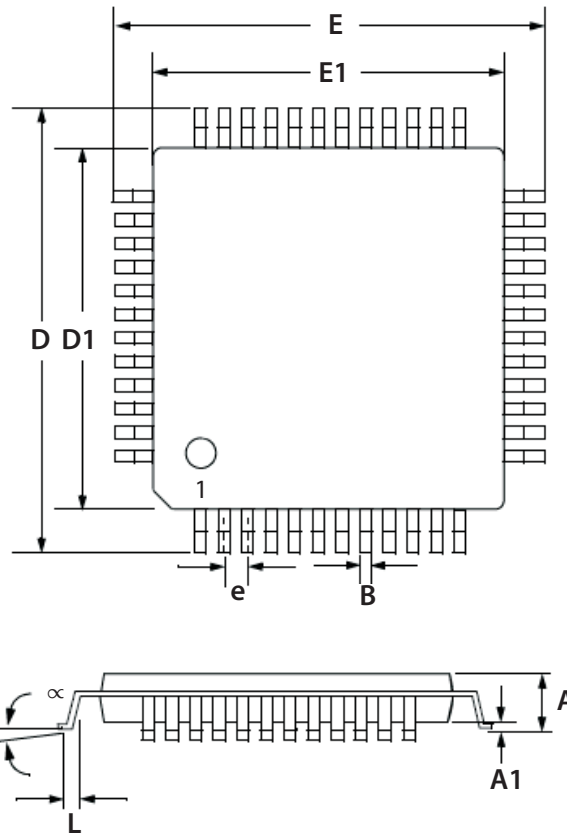

Figure 27. Typical Connection Diagram

9. Package Information

9.1 48L LQFP PACKAGE DRAWING



DIM	INCHES			MILLIMETERS		
	MIN	NOM	MAX	MIN	NOM	MAX
A	—	0.055	0.063	—	1.40	1.60
A1	0.002	0.004	0.006	0.05	0.10	0.15
B	0.007	0.009	0.011	0.17	0.22	0.27
D	0.343	0.354	0.366	8.70	9.0 BSC	9.30
D1	0.272	0.28	0.280	6.90	7.0 BSC	7.10
E	0.343	0.354	0.366	8.70	9.0 BSC	9.30
E1	0.272	0.28	0.280	6.90	7.0 BSC	7.10
e*	0.016	0.020	0.024	0.40	0.50 BSC	0.60
L	0.018	0.24	0.030	0.45	0.60	0.75
α	0.000°	4°	7.000°	0.00°	4°	7.00°

* Nominal pin pitch is 0.50 mm

Controlling dimension is mm. JEDEC Designation: MS026

THERMAL CHARACTERISTICS

Parameter	Symbol	Min	Typ	Max	Unit
Allowable Junction Temperature		—	—	135	°C
Package Thermal Resistance	θ_{JA}	—	48	—	°C/W
	θ_{JC}	—	15	—	